

2007 Chevrolet EQUINOX

Submodel: LT | Engine Type: V6 | Liters: 3.4

Fuel Delivery: FI | Fuel: GAS

Transmission Fluid Cooler Hose/Pipe Quick-Connect Fitting Disconnection and Connection

Removal Procedure

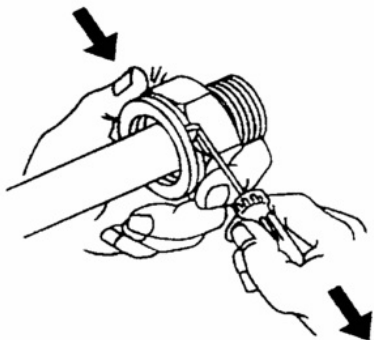

[Click to Enlarge](#)

Important

Perform the following procedure when removing the retaining rings and cooler lines from the quick connect fittings located on the radiator and/or the transmission.

1. Pull the plastic cap back from the quick connect fitting and down along the cooler line about 5 cm (2 in).
2. Using a bent-tip screwdriver, pull on one of the open ends of the retaining ring in order to rotate the retaining ring around the quick connect fitting until the retaining ring is out of position and can be completely removed.
3. Remove the retaining ring from the quick connect fitting.
4. Discard the retaining ring.

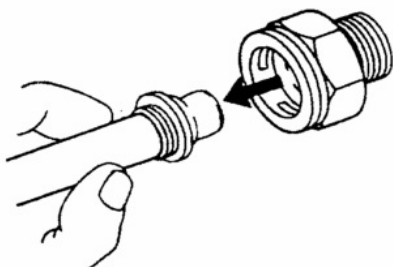

[Click to Enlarge](#)

5. Pull the cooler line straight out from the quick connect fitting.

Installation Procedure

Important

- Do not reuse any of the existing oil lines or oil line fittings if there is excessive corrosion.
 - Do not reuse any of the existing retaining rings that were removed from the existing quick connect fittings. Install new retaining rings.
 - Ensure the following procedures are performed when installing the new retaining rings onto the fittings.
1. Install a new retaining ring into the quick connect fitting using the following procedure:

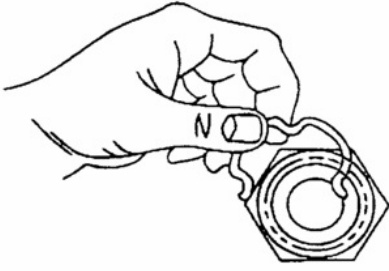

[Click to Enlarge](#)

- Hook one of the open ends of the retaining ring in one of the slots in the quick connect fitting.

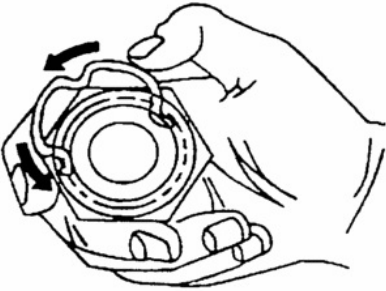

[Click to Enlarge](#)

- Rotate the retaining ring around the fitting until the retaining ring is positioned with all three ears through the three slots on the fitting.

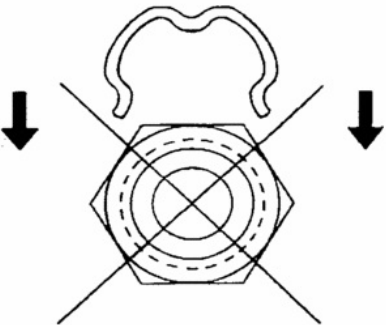

[Click to Enlarge](#)

- Do not install the new retaining ring onto the fitting by pushing the retaining ring.

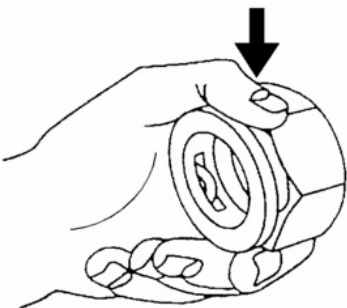

[Click to Enlarge](#)

- Ensure that the three retaining ring ears are seen from inside the fitting and that the retaining ring moves freely in the fitting slots.

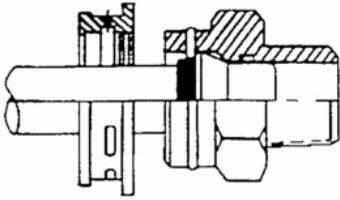

[Click to Enlarge](#)

6. Install the cooler line into the quick connect fitting.
7. Insert the cooler line end into the quick connect fitting until a click is either heard or felt.

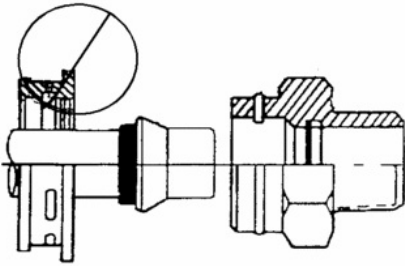

[Click to Enlarge](#)

8. Do not use the plastic cap on the cooler line in order to install the cooler line into the fitting.
9. Pull back sharply on the cooler line in order to ensure that the cooler line is fastened into the quick connect fitting.

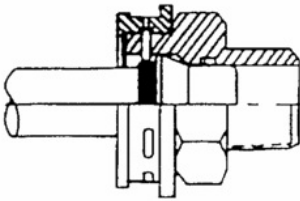

[Click to Enlarge](#)

Important

Do not manually depress the retaining clip when installing the plastic cap.

10. Position (snap) the plastic cap onto the fitting. Do not manually depress the retaining ring when installing the plastic cap onto the quick connect fitting.
11. Ensure that the plastic cap is fully seated against the fitting.

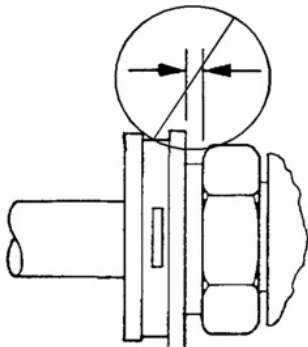

[Click to Enlarge](#)

12. Ensure that no gap is present between the cap and the fitting.

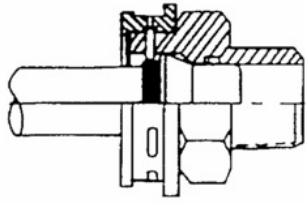

[Click to Enlarge](#)

13. Ensure that the yellow identification band on the tube is hidden within the quick connect fitting.

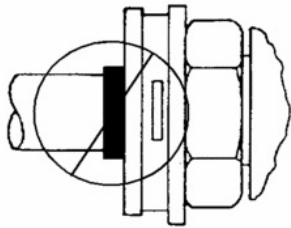

[Click to Enlarge](#)

14. A hidden yellow identification band indicates proper joint seating.
15. Fill the transmission to the proper level with the recommended transmission fluid. Refer to Sealers, Adhesives, and Lubricants and Transmission Fluid Check .