

# REMY TECHNICAL SERVICE BULLETIN

**Remy Power Products is continuously adding technical training and technical information. We welcome suggestions. If there is something technical you would like to see us add, have comments or need technical assistance, please contact us.**

## **Diagnostic and troubleshooting procedures for GM Body Control Module Code B1516 Battery Current Performance Signal (GM vehicles 2006 and up)**

Regulated Voltage Control (RVC) is GMs' platform for computer controlled charging systems. This system is designed to raise and lower the alternator's voltage set point based on vehicle electrical needs. This maximizes charging system efficiency by reducing voltage output when higher voltages are not required. The system uses the Powertrain Control Module (PCM) along with a Body Control Module (BCM) to monitor battery state of charge, vehicle electrical loads, under hood temperatures and vehicle conditions. The BCM then calculates the optimum voltage set point and communicates the desired set point to the PCM. The PCM then commands and monitors the voltage regulation.

General Motors vehicles equipped with RVC utilize a battery current sensor to measure current flow into and out of the vehicle's battery. This current sensor sends a variable duty cycle signal to the BCM to aid in calculating the voltage set point. When there is a failure with the current sensor, a Diagnostic Trouble Code (DTC) will be set and the battery warning light will illuminate.

### **DTC B1516 08 Battery Current Sensor Performance Signal Invalid DTC B1516 66 Battery Current Sensor Performance Wrong Mounting Position**

The BCM sends 5 volts and supplies a ground to the battery current sensor. The battery current sensor is an amp clamp that measures current flow into and out of the battery. The current sensor then translates flow into a variable duty cycle signal. The sensor then sends this variable duty cycle to the BCM to indicate current flow. The BCM monitors this current flow and sets a B1516 08 code if the variable duty cycle is outside the range of 5-95%. The BCM will set a B1516 66 code if polarity is reversed. This code can also be set if using a battery charger without placing the chargers ground onto the engine block.

When a DTC is set in the PCM, the RVC system will be deactivated. The alternator will default to a voltage set point of 13.8 volts and will self-excite via the microprocessor in the regulator.

### **Battery Current Sensor Circuit Testing**

Keep in mind the sensor is in a highly corrosive area. Give the battery current sensor a thorough cleaning, apply dielectric grease and reconnect. If the DTC reappears continue with diagnostics. Not all models are the same, so refer to specific vehicle wiring schematics for terminal locations.

Example wiring schematic from a 2009 Chevrolet Impala.

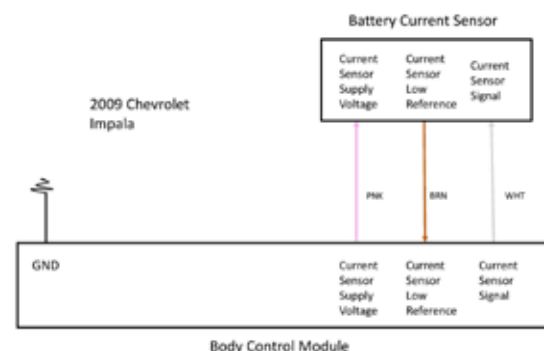

Phone: 800.854.0076

Email: TCS@remyinc.com

Hours: 8 AM – 7 PM CST

## Battery Current Sensor Circuit Testing cont'd

1. If the battery cables or battery current sensor have been replaced, ensure the current sensor is mounted in the correct direction on the battery cable. The current sensor will have a tape tab to indicate mounting direction.
  - If originally mounted on the negative cable, the tape tab direction should be away from the battery.
  - If originally mounted on the positive cable, the tape tab will be toward the battery.
  
2. With the ignition switched to the off position and scan tool removed from the data link connector, remove BCM fuse from the power distribution center. Wait for 60 seconds. Turn your digital volt ohm meter (DVOM) to ohms. Place one lead to ground and the other to the low voltage reference wire (refer to wiring schematics for specific vehicle).
  - If the reading is greater than 5 ohms, test the low voltage reference circuit and the BCM ground circuits for high resistance.
  - If the reading is 0 ohms or lower, check for open circuit.
  
3. Return BCM fuse into place and turn ignition on. Test the voltage supply terminal.
  - If voltage is less than 4.5 to 5.5 volts, test circuit for open, high resistance or short to ground.
  - If voltage is higher than 5.5 volts, test the circuit for a short to voltage.
  
4. With the ignition switched on and engine off, test the current sensor signal.
  - If voltage is less than 4.5 to 5.5 volts, test circuit for open, high resistance or short to ground.
  - If voltage is higher than 5.5 volts, test the circuit for a short to voltage.
  
5. Start the vehicle and add electrical loads. Turn DVOM to duty cycle. Ground the black lead, then take the red lead and back probe the current sensor signal terminal of the battery current sensor.
  - If no duty cycle signal is present, replace battery current sensor.
  - If duty cycle signal is present, possible BCM issue.



**Need help? Contact Technical Support  
at 800-854-0076.**

**Want to learn more? Ask your sales representative  
about Remy Products training courses.**



**REMY** POWER PRODUCTS

**Remy Power Products**  
4400 Prime Parkway  
McHenry, IL 60050 USA  
800-854-0076  
[remyautoparts.com](http://remyautoparts.com)