

## Cooling System Draining and Filling

### Tools Required

[J 26568](#) Coolant and Battery Tester

### Draining Procedure

**Caution:** With a pressurized cooling system, the coolant temperature in the radiator can be considerably higher than the boiling point of the solution at atmospheric pressure. Removal of the surge tank cap, while the cooling system is hot and under high pressure, causes the solution to boil instantaneously with explosive force. This will cause the solution to spew out over the engine, the fenders, and the person removing the cap. Serious bodily injury may result.

1. Park the vehicle on a level surface.
2. Remove the coolant pressure cap.
3. Raise and support the vehicle. Refer to [Lifting and Jacking the Vehicle](#) in General Information.
4. Place a drain pan under the lower radiator hose.
5. Remove the clip from the radiator hose quick connect at the radiator.

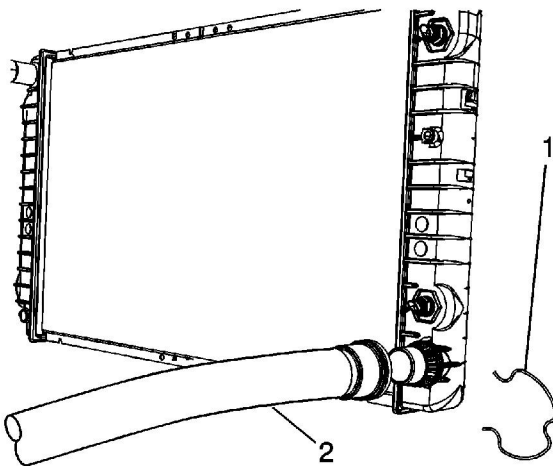

6. Remove the lower radiator hose from the radiator.
7. Drain the cooling system.
8. If a complete engine block drain is required, remove the engine block drain plug.
9. Inspect the coolant.
10. Follow the appropriate procedure based on the condition of the coolant.
  - Normal in appearance--Follow the filling procedure.
  - Discolored--Follow the flush procedure. Refer to [Flushing](#) .

### Filling Procedure

© 2020 General Motors Corporation. All rights reserved.

**Notice:** The procedure below must be followed. Improper coolant level could result in a low or high coolant level condition, causing engine damage.

1. Place the clip (1) into the hose and connect the lower radiator hose (2).

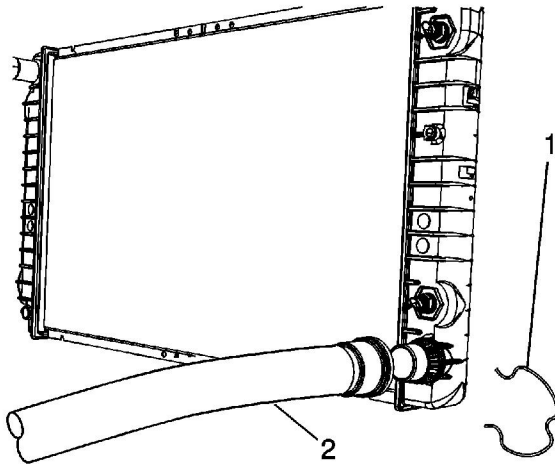

2. Apply firm pressure until you hear the clip engage.
3. Gently tug on the hose to ensure the clip is properly seated.
4. If the engine block drain plug was removed, perform the following:
  - 4.1. Apply pipe sealer to the drain plug.
  - 4.2. Install the drain plug.

### **Tighten**

Tighten the drain plug to 22 N·m (16 lb ft).

5. Lower the vehicle.
6. Using the [J 38185](#) , position the upper radiator hose clamp at the radiator.
7. Remove the upper radiator hose from the radiator.
8. Remove the coolant air bleed hose from the radiator.

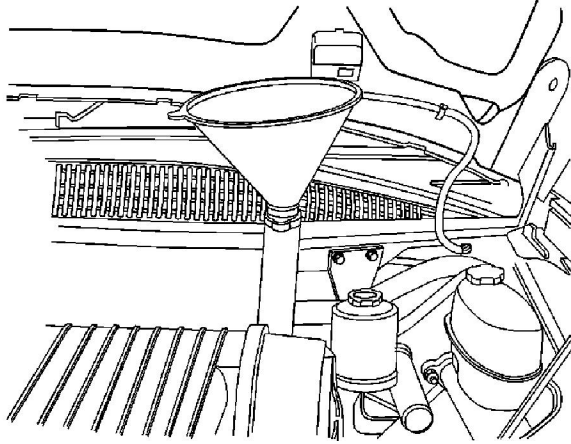

9. Place a funnel into the upper radiator hose.

**Important:** Use a 50/50 mixture of DEX-COOL antifreeze and deionized water.

10. Slowly fill the cooling system through the upper radiator hose with a 50/50 coolant mixture until the coolant comes out the coolant air bleed hose. Refer to [Approximate Fluid Capacities](#) in General Information.
11. Connect the upper radiator hose to the radiator.
12. Using the [J 38185](#) position the radiator hose clamp into the original position on the hose.
13. Connect the coolant air bleed hose to the radiator.
14. Fill the radiator with coolant through the filler neck.
15. Install the coolant pressure cap.
16. Fill the coolant overflow bottle to the full line.
17. Start the engine.
18. Run the engine at 2,000-2,500 RPM until the engine reaches normal operating temperature.
19. Allow the engine to idle for 3 minutes.
20. Shut the engine OFF.
21. Allow the engine to cool.
22. Top off the coolant as necessary.
23. Inspect the concentration of the engine coolant, using the [J 26568](#).
24. Rinse away any excess coolant from the engine and the engine compartment.
25. Inspect the cooling system for leaks.