

2021 ACCESSORIES & EQUIPMENT

Power Outlets - Express/Savana

SPECIFICATIONS

FASTENER SPECIFICATIONS

Reusable Threaded Fastener Tightening Specifications

NOTE:

All fasteners listed in this table can be reused after removal.

Application	Specification
	Metric (English)
Accessory AC and DC Power Control Module Bolt	9 N.m (80 lb in)

SCHEMATIC WIRING DIAGRAMS

CIGAR LIGHTER/POWER OUTLET WIRING SCHEMATICS

Cigar Lighter/Power Outlet

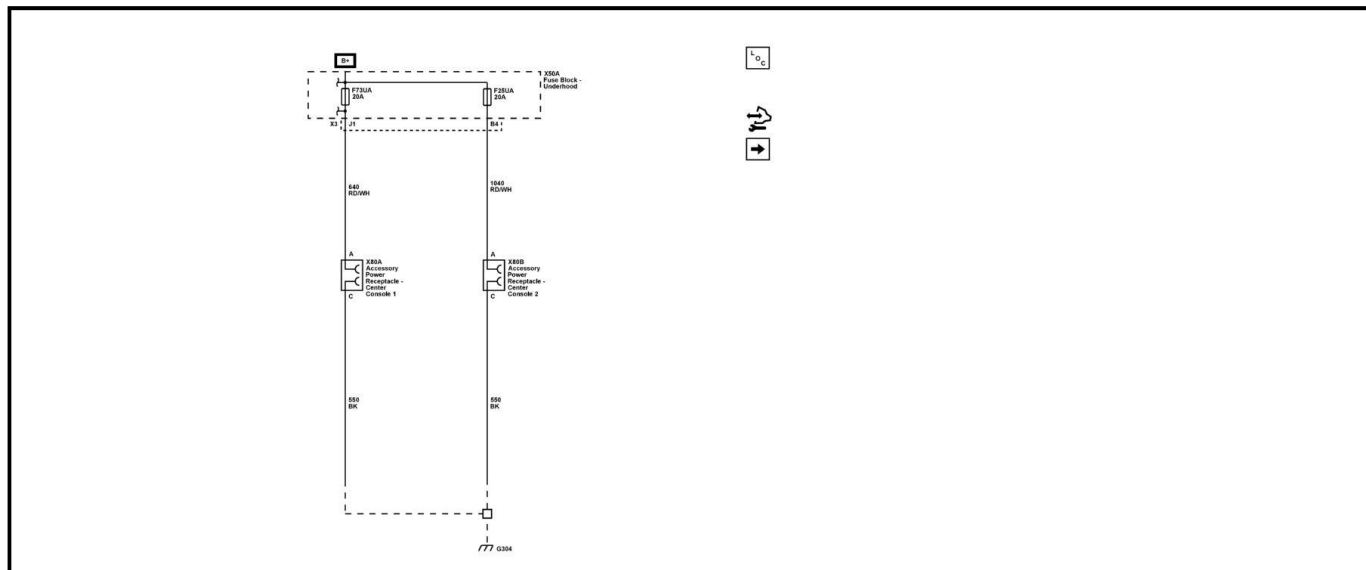

110 V AC Outlet (KI4)

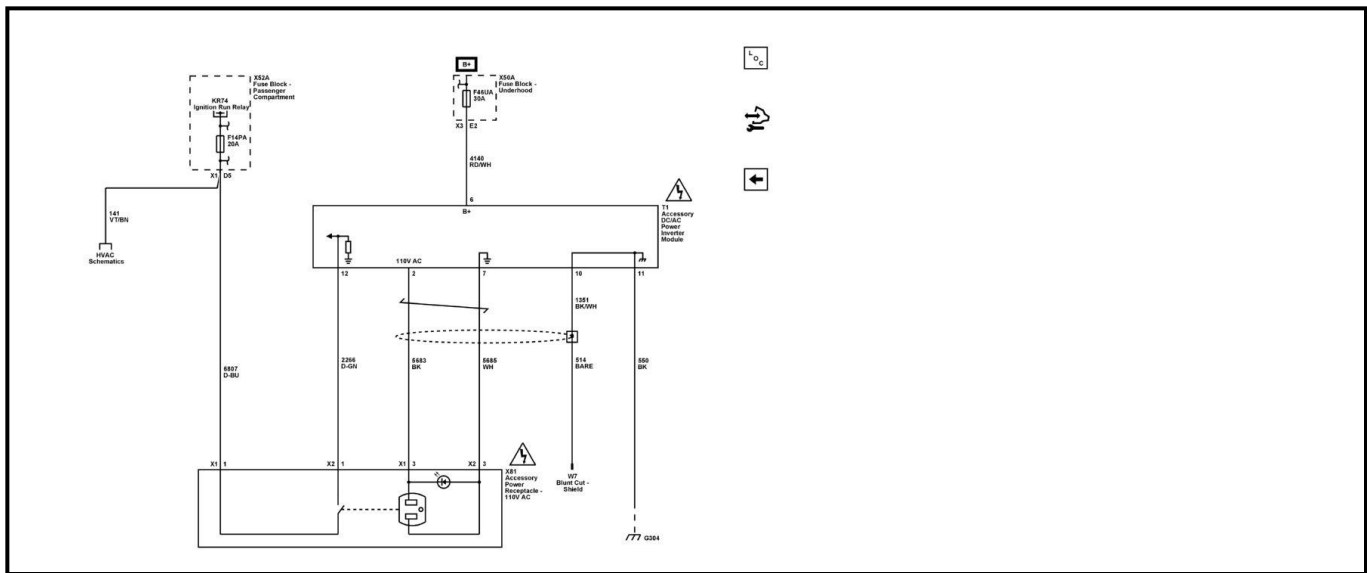

DIAGNOSTIC INFORMATION AND PROCEDURES

SYMPTOMS - POWER OUTLETS

Visual/Physical Inspection

- Inspect for aftermarket devices which can affect the operation of the power outlets.
- Inspect the accessible system components or the visible system components for obvious damage or for obvious conditions which can cause the symptom.

Intermittent

Electrical connections or wiring may be the cause of intermittent conditions. Refer to [Testing for Intermittent Conditions and Poor Connections](#)

Symptom List

Refer to [Power Outlet Receptacle Malfunction \(12 V\)](#), or [Power Outlet Receptacle Malfunction \(110 V\)](#) in order to diagnose the system.

POWER OUTLET RECEPTACLE MALFUNCTION (12 V)

Diagnostic Instructions

- Perform the [Diagnostic System Check - Vehicle](#) prior to using this diagnostic procedure.
- Review [Strategy Based Diagnosis](#) for an overview of the diagnostic approach.
- [Diagnostic Procedure Instructions](#) provides an overview of each diagnostic category.

Diagnostic Fault Information

Circuit	Short to Ground	Open/High Resistance	Short to Voltage	Signal Performance
B+	1	1	-	-
Ground	-	1	-	-

1. Accessory Power Receptacle Malfunction

Circuit/System Description

The accessory power receptacles and cigarette lighter receptacle are supplied B+ all the time.

Reference Information

Schematic Reference

[Cigar Lighter/Power Outlet Wiring Schematics](#)

Connector End View Reference

[Master Electrical Component List](#) , or [Component Connector End Views - Index](#)

Description and Operation

[Power Outlets Description and Operation](#)

Electrical Information Reference

- [Circuit Testing](#)
- [Connector Repairs](#)
- [Testing for Intermittent Conditions and Poor Connections](#)
- [Wiring Repairs](#)

[Circuit/System Testing](#)

1. Ignition OFF, disconnect the harness connector at the appropriate accessory power receptacle or cigarette lighter receptacle.
2. Test for less than 5 Ω between the ground circuit terminal C and ground.
 - If greater than the specified range, test the ground circuit for an open/high resistance.
3. Verify that a test lamp illuminate between the B+ circuit terminal A and ground.
 - If test lamp does not illuminate, test the B+ circuit for a short to ground or an open/high resistance.
4. If the circuits test normal, test or replace the accessory power receptacle.

[Repair Instructions](#)

Perform the [Diagnostic Repair Verification](#) after completing the diagnostic procedure.

POWER OUTLET RECEPTACLE MALFUNCTION (110 V)

[Diagnostic Instructions](#)

- Perform the [Diagnostic System Check - Vehicle](#) prior to using this diagnostic procedure.
- Review [Strategy Based Diagnosis](#) for an overview of the diagnostic approach.
- [Diagnostic Procedure Instructions](#) provides an overview of each diagnostic category.

[Diagnostic Fault Information](#)

Circuit	Short to Ground	Open/High Resistance	Short to Voltage	Signal Performance
B+	1	1	-	-
Ignition	1	1	-	-
AC Terminal 2	1	1	1	-
AC Terminal 7	1	1	1	-
Signal	1	1	2	-
Ground	-	1	-	-

1. Accessory DC/AC Power Inverter Module Always OFF
2. Accessory DC/AC Power Inverter Module Always ON

[Circuit/System Description](#)

The accessory DC/AC power inverter module converts 12 V direct current (DC) battery voltage to 110 - 120 V alternating current (AC) in order to operate AC powered devices. The accessory DC/AC power inverter module provides up to 150 watts of power. The accessory DC/AC power inverter module is connected to a chassis ground circuit and receives fuse protected battery voltage.

The accessory power receptacle has an internal switch, that detects when an AC powered device is plugged into the receptacle. When the ignition is ON and an AC powered device is plugged into the accessory power receptacle, the normally open switch in the accessory power receptacle, closes. When the accessory DC/AC power inverter module detects the voltage from the accessory power receptacle switch, the inverter module begins to supply 110 - 120 V AC to the accessory power receptacle - 110 V AC after a 1.5 s delay.

Reference Information

Schematic Reference

Cigar Lighter/Power Outlet Wiring Schematics

Connector End View Reference

Master Electrical Component List , or Component Connector End Views - Index

Description and Operation

Power Outlets Description and Operation

Electrical Information Reference

- [Circuit Testing](#)
- [Connector Repairs](#)
- [Testing for Intermittent Conditions and Poor Connections](#)
- [Wiring Repairs](#)

Circuit/System Testing

WARNING: To help avoid personal injury, always treat the accessory power receptacle, accessory DC/AC power inverter module, AC circuit wires, and connectors as if AC high-voltage is present.

1. Ignition OFF, scan tool disconnected, ignition key removed. Wait for 2 min. Nothing plugged into the X81 Accessory Power Receptacle - 110 V AC, disconnect the harness connector at the T1 Accessory DC/AC Power Inverter Module.
2. Test for less than 10 Ω between the ground circuit terminal 11 and ground.
 - **If greater than 10 Ω**
 1. Ignition OFF.
 2. Test for less than 2 Ω in the ground circuit end to end.
 - If 2 Ω or greater, repair the open/high resistance in the circuit.
 - If less than 2 Ω , repair the open/high resistance in the ground connection.
 - **Go to next step: If less than 10 Ω**
3. Verify that a test lamp illuminates between the B+ circuit terminal 6 and ground.
 - **If the test lamp does not illuminate and the circuit fuse is good**
 1. Ignition OFF.
 2. Test for less than 2 Ω in the B+ circuit end to end.
 - If greater than 2 Ω , repair the open/high resistance in the circuit.
 - If less than 2 Ω , verify the fuse is not open and there is voltage at the fuse.

- **If the test lamp does not illuminate and the circuit fuse is open**

1. Ignition OFF.

2. Test for infinite resistance between the B+ circuit terminal 6 and ground.

- If less than infinite resistance, repair the short to ground on the circuit.
- If infinite resistance, replace the T1 Accessory DC/AC Power Inverter Module.

- **Go to next step: If the test lamp illuminates**

4. Test for less than 1 V between the signal circuit terminal 12 and ground.

- **If greater than 1 V**

Repair the short to voltage in the signal circuit.

- **Go to next step: If less than 1 V**

5. Test for infinite resistance between the signal circuit terminal 12 and ground.

- **If less than infinite resistance**

Repair the short to ground in the signal circuit.

- **Go to next step: If infinite resistance**

6. Test for less than 1 V between the AC circuit terminals listed below and ground.

- AC Terminal 2
- AC Terminal 7
- **If greater than 1 V**

Repair the short to voltage in the AC circuit.

- **Go to next step: If less than 1 V**

7. Test for infinite resistance between the AC circuit terminals listed below and ground:

- AC Terminal 2
- AC Terminal 7
- **If less than infinite resistance**

Repair the short to ground in the AC circuit.

- **Go to next step: If infinite resistance**

8. Disconnect X1 and X2 harness connectors at the X81 Accessory Power Receptacle - 110 V AC.

9. Test for less than 2 Ω between the AC circuit terminals listed below:

- X81 Accessory Power Receptacle - 110 V AC terminal 3 X 1 and the T1 Accessory DC/AC Power Inverter Module terminal 2.
- X81 Accessory Power Receptacle - 110 V AC terminal 3 X 2 and the T1 Accessory DC/AC Power Inverter Module terminal 7.
- **If greater than 2 Ω**

Repair the open/high resistance in the AC circuit.

- **Go to next step: If less than 2 Ω**

10. Ignition ON.

11. Verify that a test lamp illuminates between the ignition voltage circuit terminal 1 X 1 and ground.

- **If the test lamp does not illuminate and the circuit fuse is good**

1. Ignition OFF.

2. If less than 2 Ω , verify the fuse is not open and there is voltage at the fuse.

- If greater than 2 Ω , repair the open/high resistance in the circuit.

- If less than 2 Ω , refer to **Power Mode Mismatch** .
 - **If the test lamp does not illuminate and the circuit fuse is open**
 1. Ignition OFF.
 2. Test for infinite resistance between the ignition voltage circuit terminal 1 X 1 and ground.
 - If less than infinite resistance, repair the short to ground on the circuit.
 - If infinite resistance, replace the T1 Accessory DC/AC Power Inverter Module.
 - **Go to next step: If the test lamp illuminates**
12. Ignition OFF, connect all harness connectors at the X81 Accessory Power Receptacle - 110 V AC. Connect a 110 V extension cord without a connected device to the X81 Accessory Power Receptacle - 110 V AC, ignition ON.
13. Verify that a test lamp illuminates between the T1 Accessory DC/AC Power Inverter Module signal circuit terminal 12 and ground.
- **If the test lamp does not illuminate**
 1. Ignition OFF.
 2. Test for less than 2 Ω in the signal circuit end to end.
 - If greater than 2 Ω , repair the open/high resistance in the circuit.
 - If less than 2 Ω , replace the X81 Accessory Power Receptacle - 110 V AC.
 - **Go to next step: If the test lamp illuminates**
14. Test or replace the T1 Accessory DC/AC Power Inverter Module.

Component Testing

Accessory Power Outlet 110 V AC

1. Ignition OFF, remove the X81 Accessory Power Receptacle - 110 V AC.
2. Test for infinite resistance between terminal 3 X 2 and terminal 3 X 1.
 - **If less than infinite resistance**
Replace X81 Accessory Power Receptacle - 110 V AC.
3. Test for less than 2 Ω between the following terminals:
 - Terminal 3 X 2 and the applicable receptacle terminal
 - Terminal 3 X 1 and the applicable receptacle terminal
 - **If greater than the 2 Ω**
Replace the X81 Accessory Power Receptacle - 110 V AC.
4. Test for infinite resistance between terminal 1 X 1 and terminal 1 X 2.
 - **If less than the specified range**
Replace X81 Accessory Power Receptacle - 110 V AC.
 - **Go to next step: If infinite resistance**
5. Connect a 110 V extension cord without a connected device to the X81 Accessory Power Receptacle - 110 V AC.
6. Test for less than 5 Ω between terminal 1 X 1 and terminal 1 X 2.
 - **If greater than the 5 Ω**
Replace the X81 Accessory Power Receptacle - 110 V AC.
 - **Go to next step: If less than 5 Ω**
7. All OK

Repair Instructions

Perform the [Diagnostic Repair Verification](#) after completing the repair.

[Accessory AC and DC Power Control Module Replacement](#)

REPAIR INSTRUCTIONS

CIGARETTE LIGHTER RECEPTACLE REPLACEMENT

Special Tools

EL-42059 Cigar Lighter Socket Remover

Equivalent regional tools: [Special Tools](#)

Removal Procedure

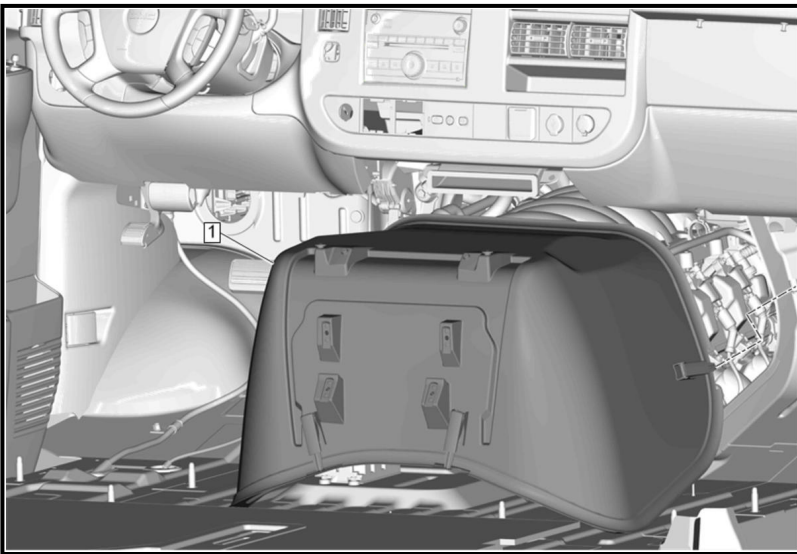

1.

Engine Cover (1) - Remove - [Engine Cover Replacement](#)

2. Remove the auxiliary power outlet fuse from the fuse block.

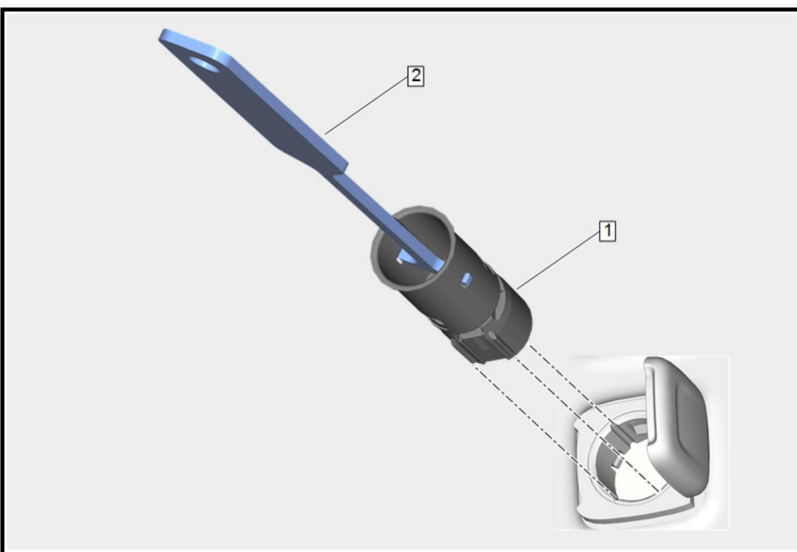

3.

Remove the cigarette lighter receptacle (1):

1. Look into the receptacle (1). There are two 3 mm (0.11 in) tab windows 12 mm (0.47 in) from the front of the receptacle. The **EL-42059** Cigar Lighter Socket Remover (2) pushes the plastic latches

from these tab windows and the receptacle can be pulled straight out.

2. Place one side of the "T" portion of the **EL-42059** Cigar Lighter Socket Remover (2) into the tab window. The **EL-42059** Cigar Lighter Socket Remover will not fit straight into the receptacle (1). Angle the **EL-42059** Cigar Lighter Socket Remover slightly for insertion into the receptacle.
3. Insert the other side of the "T" into the opposite tab window.

You must move the **EL-42059** Cigar Lighter Socket Remover (2) handle toward horizontal to engage the other tab window.

4. Use the **EL-42059** Cigar Lighter Socket Remover (2) to pull the receptacle (1) straight out.
4. If **EL-42059** Cigar Lighter Socket Remover (2) fails to release the receptacle (1) from the retainer, perform the following alternate method:
 1. Insert a small grinding tool with a cutoff wheel into the socket.
 2. Remove the plastic latches in the 3 mm (0.11 in) square windows.
 3. Use the **EL-42059** Cigar Lighter Socket Remover (2) as directed above to remove the socket.

Installation Procedure

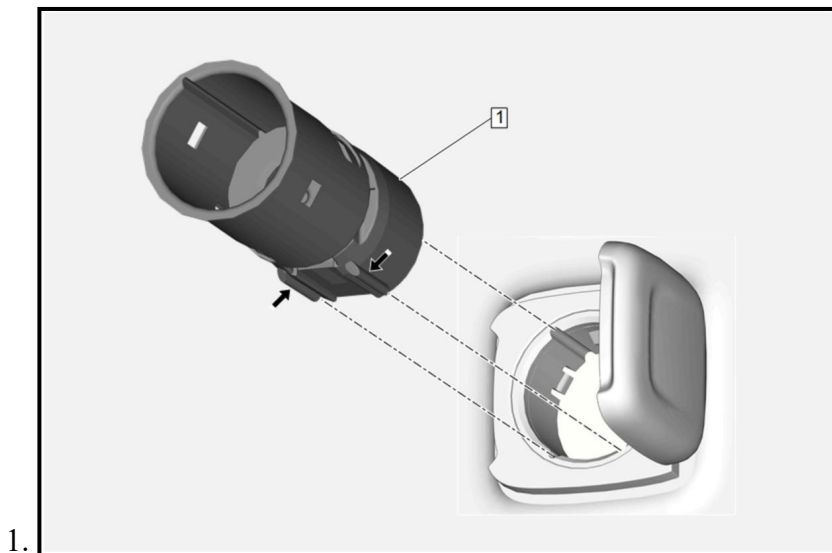

1. Route the connector through the cigarette lighter receptacle retainer. Align the retainer to the slot in the opening.
2. Install the retainer by pressing into place until fully seated.
3. Connect the electrical connector to the cigarette lighter receptacle (1).
4. Align the tabs on the receptacle (1) to the slots in the retainer. Install the accessory power receptacle by pressing into place until fully seated.
5. Install the auxiliary power outlet fuse.



6.

Engine Cover (1) - Install - [Engine Cover Replacement](#)

ACCESSORY AC AND DC POWER CONTROL MODULE REPLACEMENT

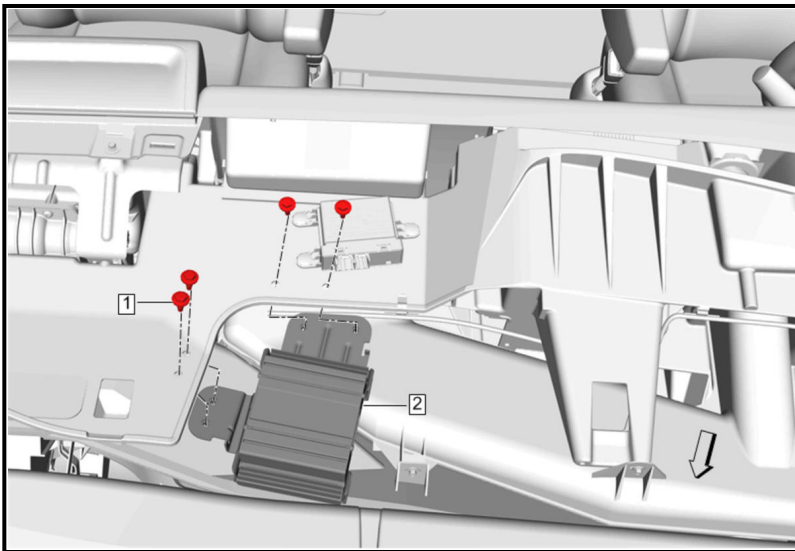

Callout	Component Name
Preliminary Procedure Instrument Panel Upper Trim Panel Replacement	
1	Accessory AC and DC Power Control Module Bolt [4x] CAUTION: Refer to Fastener Caution . Tighten 9 N.m (80 lb in)
2	Accessory AC and DC Power Control Module Procedure Disconnect the electrical connector.

120-VOLT ACCESSORY POWER RECEPTACLE REPLACEMENT

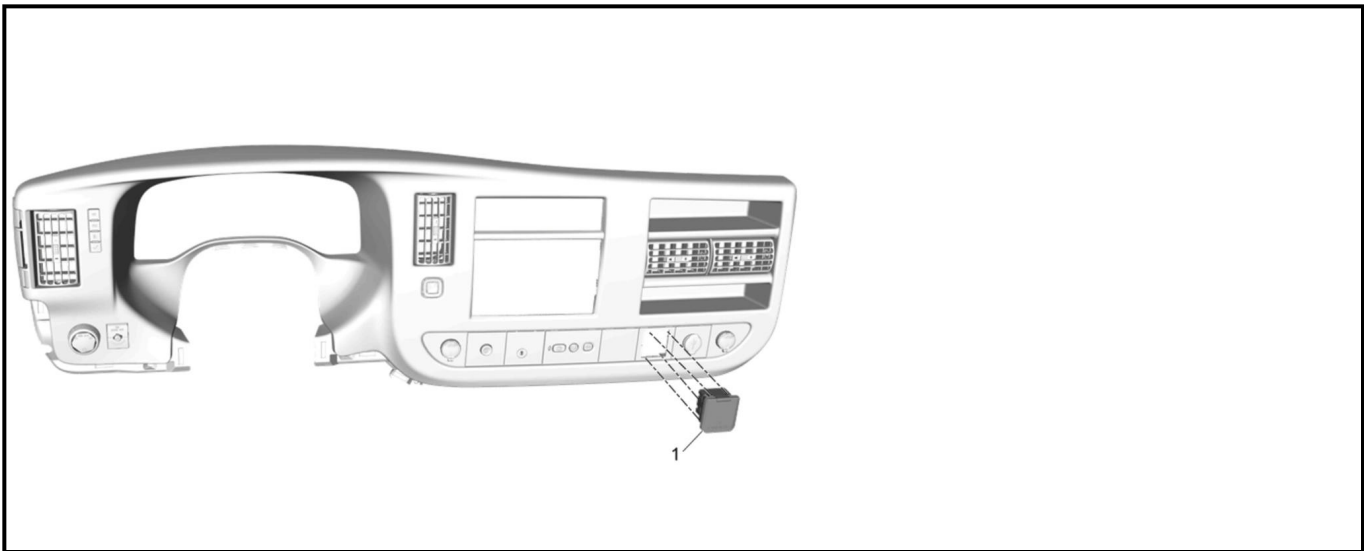

Callout	Component Name
Preliminary Procedure <u>Instrument Panel Cluster Trim Plate Replacement</u>	
1	120-Volt Accessory Power Receptacle Procedure Release the retaining tabs.

ACCESSORY POWER RECEPTACLE RETAINER REPLACEMENT

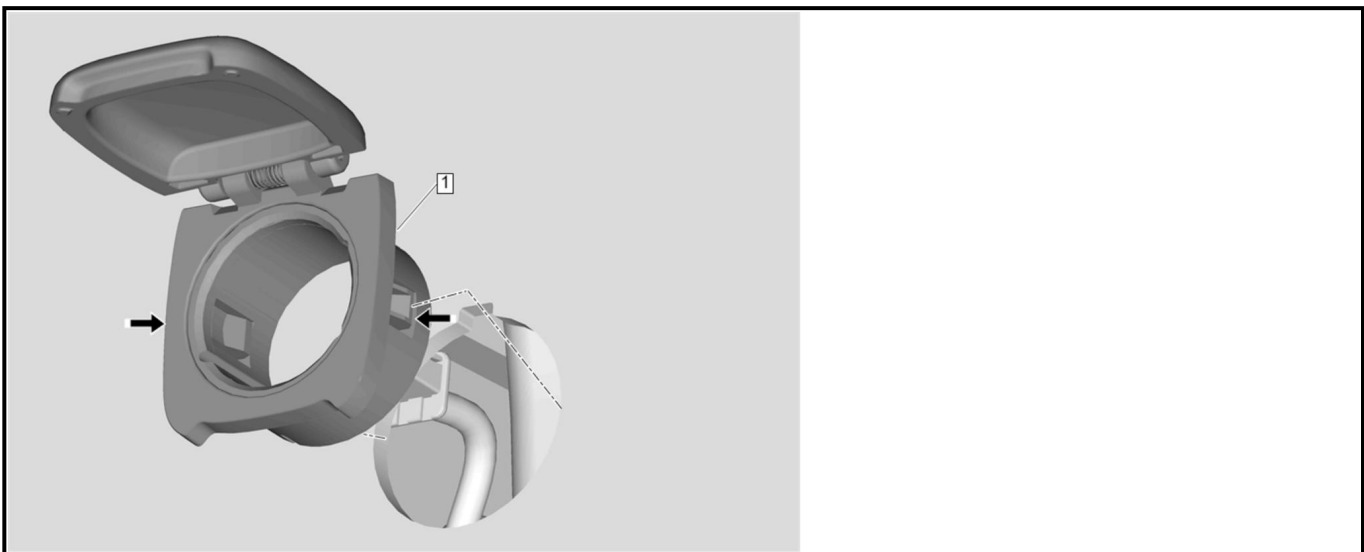

Callout	Component Name
Preliminary Procedure <u>Accessory Power Receptacle Replacement</u>	
1	Accessory Power Receptacle Retainer Procedure <ol style="list-style-type: none"> 1. Use a flat bladed plastic trim tool. 2. Release the retaining tabs.

ACCESSORY POWER RECEPTACLE REPLACEMENT

Special Tools

EL-42059 Cigar Lighter Socket Remover

Equivalent regional tools: [Special Tools](#)

Removal Procedure



Engine Cover (1) - Remove - [Engine Cover Replacement](#)

2. Remove the auxiliary power outlet fuse from the fuse block.

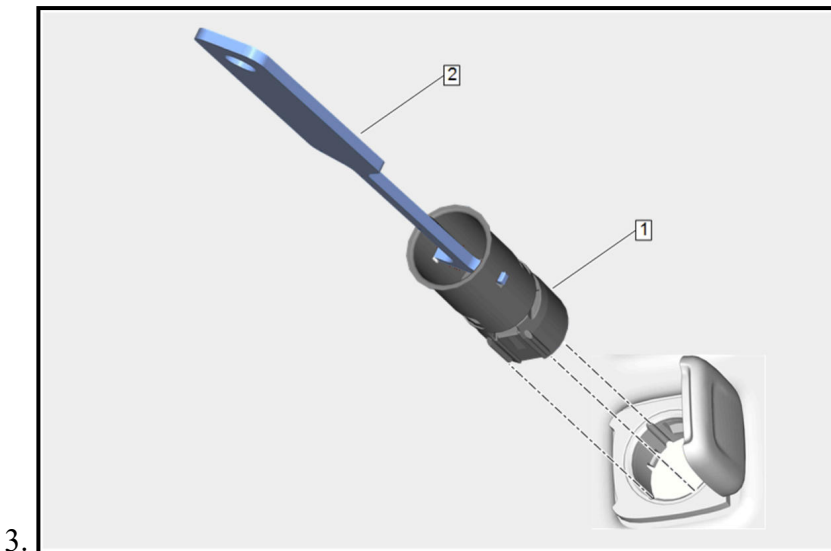

Remove the accessory power receptacle (1):

1. Look into the receptacle (1). There are two 3 mm (0.11 in) tab windows 12 mm (0.47 in) from the front of the receptacle. The **EL-42059** Cigar Lighter Socket Remover (2) pushes the plastic latches from these tab windows and the receptacle can be pulled straight out.
2. Place one side of the "T" portion of the **EL-42059** Cigar Lighter Socket Remover (2) into the tab window. The **EL-42059** Cigar Lighter Socket Remover will not fit straight into the receptacle (1). Angle the **EL-42059** Cigar Lighter Socket Remover slightly for insertion into the receptacle.
3. Insert the other side of the "T" into the opposite tab window.

You must move the **EL-42059** Cigar Lighter Socket Remover (2) handle toward horizontal to engage the other tab window.

4. Use the **EL-42059** Cigar Lighter Socket Remover (2) to pull the receptacle (1) straight out.

4. If **EL-42059** Cigar Lighter Socket Remover (2) fails to release the receptacle (1) from the retainer, perform the following alternate method:

1. Insert a small grinding tool with a cutoff wheel into the socket.

2. Remove the plastic latches in the 3 mm (0.11 in) square windows.
3. Use the **EL-42059** Cigar Lighter Socket Remover (2) as directed above to remove the socket.

Installation Procedure

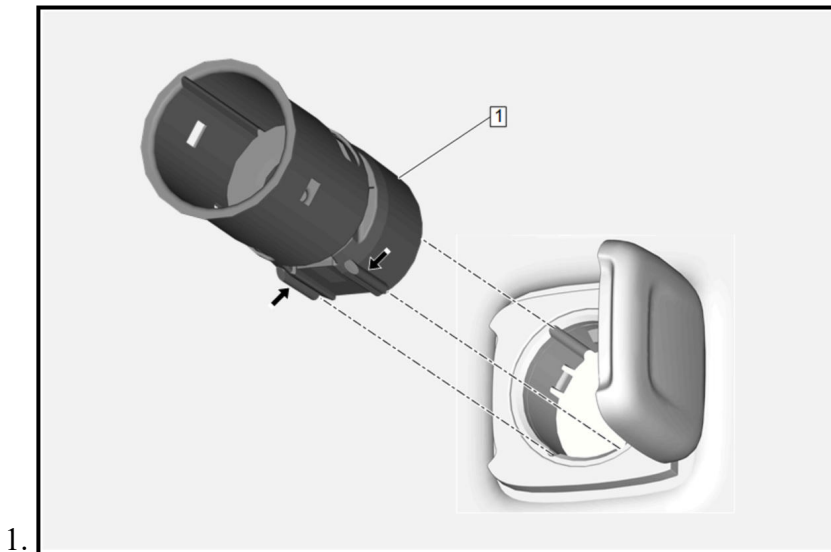

Route the connector through the accessory power receptacle retainer. Align the retainer to the slot in the opening.

2. Install the retainer by pressing into place until fully seated.
3. Connect the electrical connector to the accessory power receptacle (1).
4. Align the tabs on the receptacle (1) to the slots in the retainer. Install the accessory power receptacle by pressing into place until fully seated.
5. Install the auxiliary power outlet fuse.



Engine Cover (1) - Install - [Engine Cover Replacement](#)

DESCRIPTION AND OPERATION

POWER OUTLETS DESCRIPTION AND OPERATION

12 Volt Power Outlet Receptacle Description and Operation

The 12 V accessory power receptacles are supplied B+ all the time.

110 Volt Power Outlet Receptacle System Description

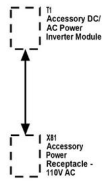

Callout	Component Name
T1	T1 Accessory DC/AC Power Inverter Module
X81	X81 Accessory Power Receptacle - 110 V AC

The alternating current (AC) accessory power outlet system consists of the accessory DC/AC power inverter module and the accessory power receptacle - 110 V AC. The accessory DC/AC power inverter module converts 12 V direct current (DC) battery power to 110 V at 60 Hertz (Hz) AC power to operate AC powered devices. The accessory DC/AC power inverter module provides up to 150 watts of power. The accessory power receptacle - 110 V AC provides the usual connection for AC powered devices.

110 Volt Power Outlet Receptacle System Operation

The accessory DC/AC power inverter module receives fuse protected battery voltage and is connected to the 12 V electrical system ground. The accessory power receptacle - 110 V AC has an internal switch, that detects when an AC powered device is plugged into the outlet. When the ignition is ON, and an AC powered device is plugged into the accessory power receptacle - 110 V AC, the normally open switch in the accessory power receptacle - 110 V AC, closes. When the accessory DC/AC power inverter module detects the voltage from the accessory power receptacle - 110 V AC switch, the inverter module begins to supply 110 V AC to the accessory power receptacle - 110 V AC after a 1.5 second delay. The accessory AC power system is protected against circuit overload and circuit shorts to ground.

110 Volt Power Outlet Receptacle Isolation Fault Protection

The accessory DC/AC power inverter module contains a ground fault circuit interrupter (GFCI). GFCI monitors the 110 V circuit for a short to vehicle chassis ground. If a 110 V AC short to ground is detected, the accessory DC/AC power inverter module will turn OFF. The module remains OFF, until the AC powered device is unplugged from the outlet, and then plugged into the outlet after a 3 second delay.

110 Volt Power Outlet Receptacle Overload Shutdown

The accessory DC/AC power inverter module will turn OFF if the current in the 110 V circuit is greater than 3.8 A for 1 second, or 2.5 A for 10 seconds. The module will turn ON again, when the AC powered device is unplugged from the outlet, and then plugged into the outlet after a 3 second delay.

110 Volt Power Outlet Receptacle Internal Shutdown

The accessory DC/AC power inverter module will turn OFF if the B+ supply voltage is greater than 16.5 V or less than 11 V. The module will also turn OFF if the device temperature is greater than 85B°C (185B°F). The module will turn ON again, after the shutdown condition is corrected, and the AC powered device is unplugged from the outlet, and then plugged into the outlet.

SPECIAL TOOLS AND EQUIPMENT

SPECIAL TOOLS

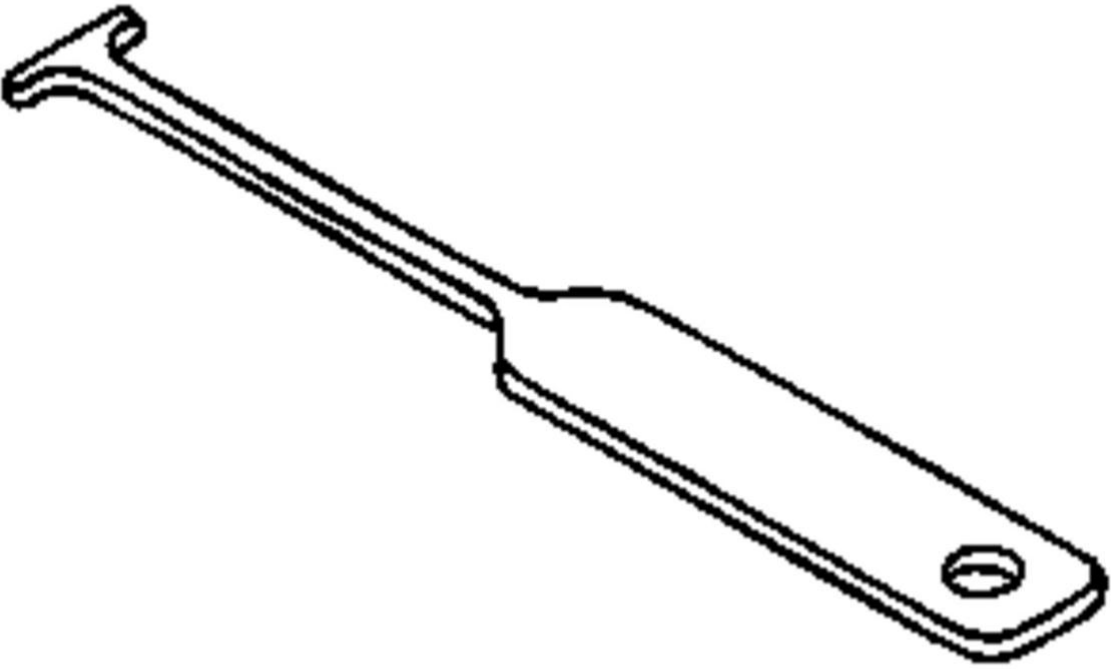
Illustration	Tool Number/ Description
 A line drawing of a long-handled tool. The handle is long and tapers slightly towards the end. At the top of the handle, there is a hook-like shape with a small notch. At the bottom of the handle, there is a circular hole. The tool is oriented diagonally from the top-left to the bottom-right.	J 42059 Cigar Lighter Socket Remover