

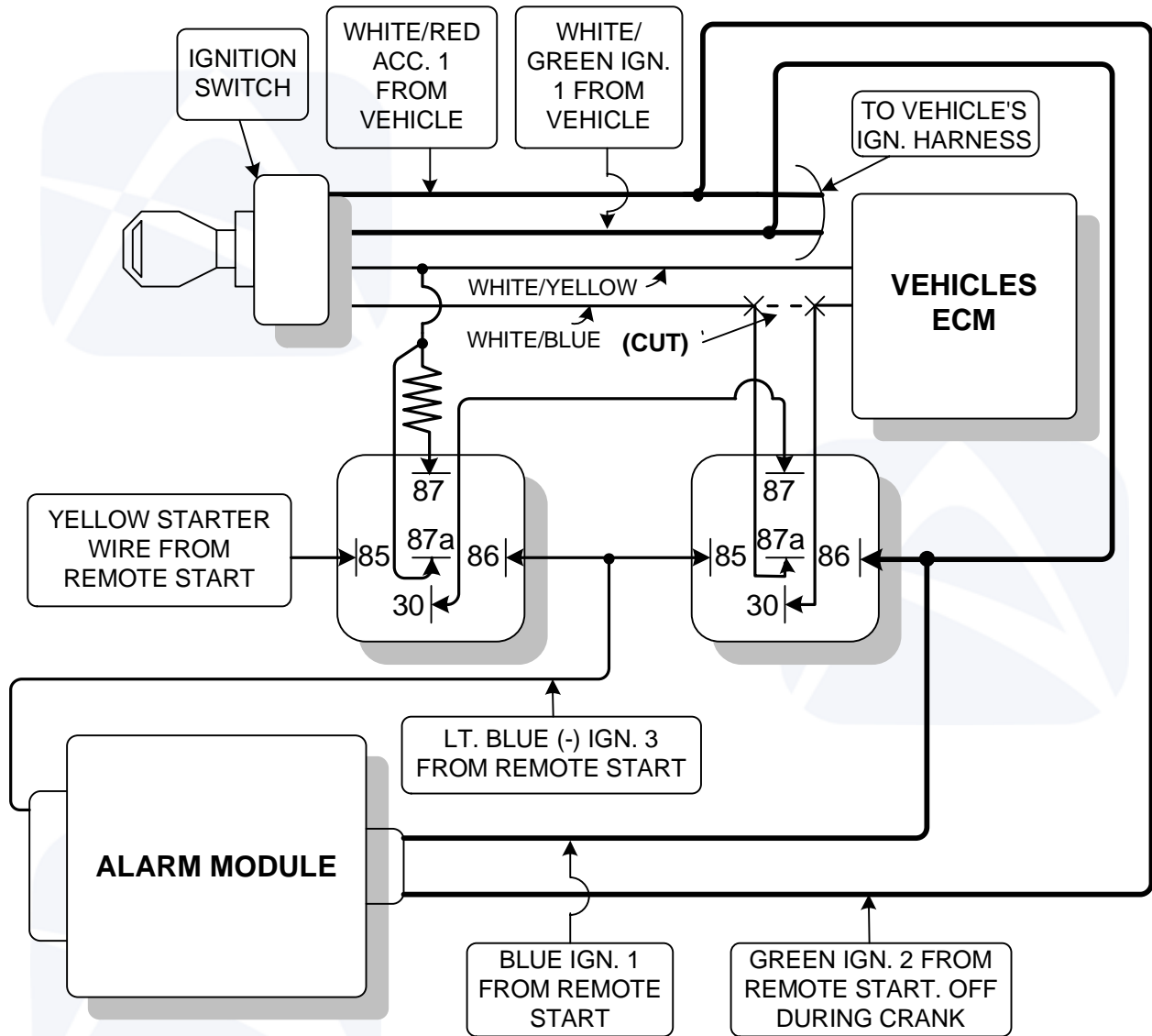

**Pass Lock bypass for the Chevy Colorado & GMC Canyon**



The above diagram shows you how to bypass the PASS LOCK system on the Chevy Colorado & GMC Canyon. This system is different from previous PASS LOCK systems. Below is the procedure for bypassing the PASS LOCK when installing a remote start.

1. Start the vehicle with the key.
2. Cut the WHITE/BLUE wire in half and strip both ends.
3. Strip back the WHITE/YELLOW wire about a 1/2 of an inch.
4. Use your Multi-Meter set on OHMS, put the red lead of the meter on the key side of the WHITE/BLUE wire and the black lead of the meter to the WHITE/YELLOW
5. Turn the vehicle to the crank position, (the vehicle will not crank again), then read the resistance on your Meter.
6. Using the proper resistor follow the above diagram.