

&lt;- Back

Forward -&gt;

Document ID# 282761  
1998 Chevrolet/Geo S10 Pickup - 2WD

Print

# Vacuum Tank Replacement

## [Removal Procedure](#)

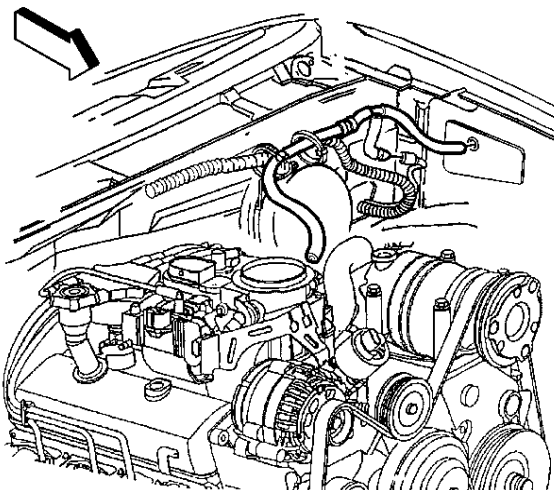

1. Remove the brake pressure modulator valve. Refer to [Brake Pressure Modulator Valve \(BPMV\) Replacement](#) in Antilock Brake System.
2. Disconnect the vacuum hose(s).

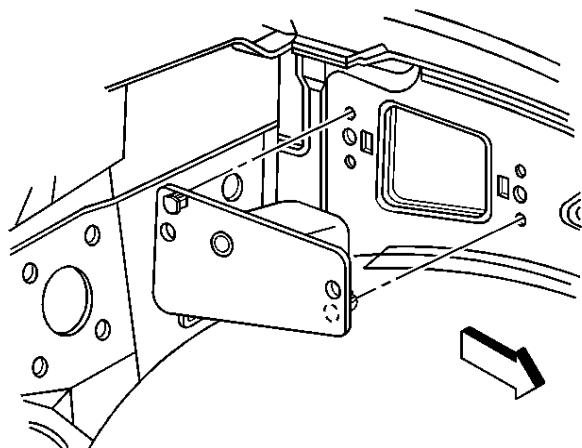

3. Use a flat-bladed tool in order to depress the retaining tabs.
4. Remove the vacuum tank.

### [Installation Procedure](#)

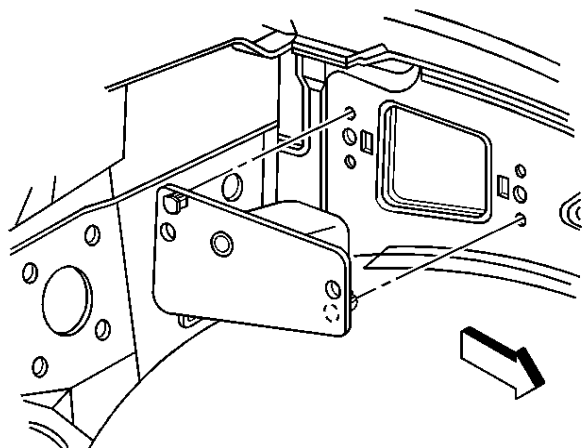

1. Install the vacuum tank. Ensure that the retaining tabs lock into place.

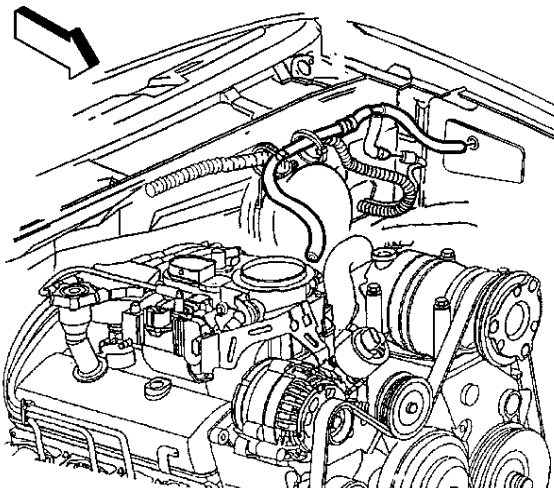



2. Install the vacuum hose(s).
3. Install the brake pressure modulator valve. Refer to [Brake Pressure Modulator Valve \(BPMV\) Replacement](#) in Antilock Brake System.

---

[<- Back](#)

[Forward ->](#)

**Document ID# 282761**  
**1998 Chevrolet/Geo S10 Pickup - 2WD**

[Print](#)