

## Front Suspension Support Brace Replacement

### Removal Procedure

1. Partially raise and support the vehicle. Refer to [Lifting and Jacking the Vehicle](#) in General Information. Allow the suspension to hang free.

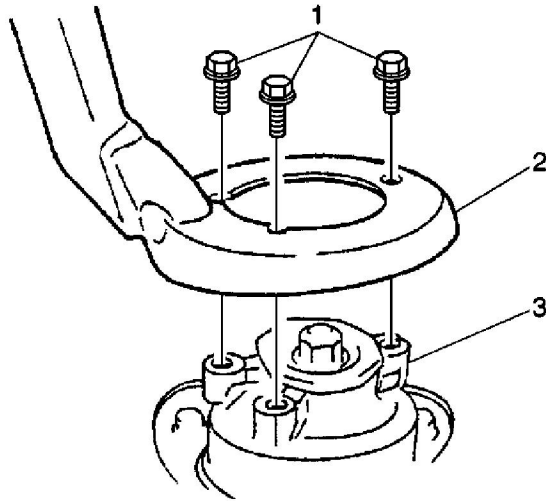

2. Remove the 3 bolts (1) and the front suspension support brace (2) from the left side of the vehicle.
3. Remove the 3 bolts and the brace from the right side of the vehicle.

### Installation Procedure

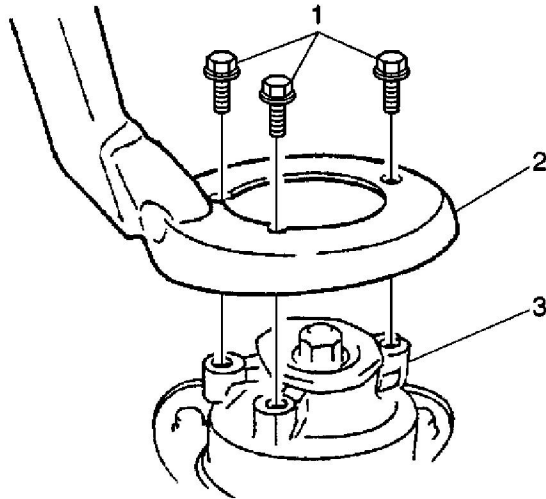

**Important:** Do not tighten the bolts.

1. Install the front suspension support brace (2) and the 3 bolts (1) to the right side of the vehicle.

**Important:** Do not tighten the bolts.

2. Install the brace and the 3 bolts to the left side of the vehicle.

If necessary, use a pry bar in order to align the bolt holes.

**Notice:** Refer to [Fastener Notice](#) in the Preface section.

3. Tighten the 6 bolts.

#### **Tighten**

Tighten the bolts to 50 N·m (36.5 lb ft).

4. Lower the vehicle.